

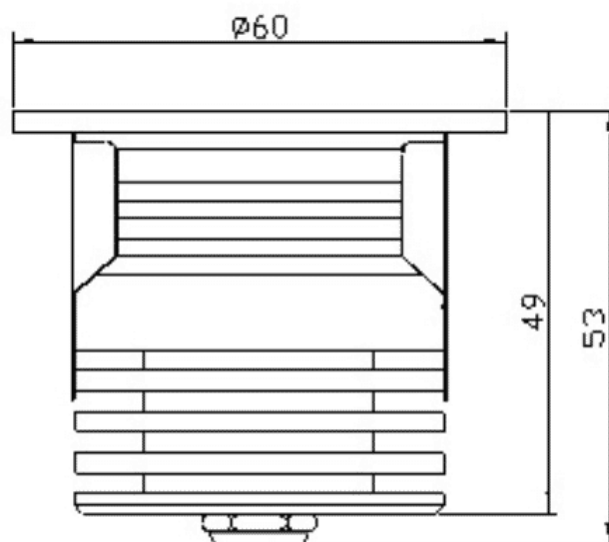

ES1015

Encastré de sol



Caractéristiques techniques

DIAMÈTRE	60,0mm
PUISSANCE MAXIMALE	2,0W, 3,0W, 6,0W
DIMENSIONS D'ENCASTREMENT	Ø49,0mm
TENSION D'ALIMENTATION	24Vdc
POIDS	525,0g
MATIÈRE	Inox 316
HAUTEUR ENCASTRÉE	51,0mm
HAUTEUR	53,0mm
CONDITIONNEMENT	1 pièce



Références

NOM COMMERCIAL RÉF. CONSTRUCTEUR	TEINTE	FLUX	EFFICACITÉ LUMINEUSE	COULEUR DU PRODUIT
ES1015BL30 ENG0600606000006	3000°K	405lm	65lm/W	Gris
ES1015BL60 ENG0600606000007	6000°K	405lm	65lm/W	Gris
ES1015ROUGE ENG0600606000009	ROUGE	45lm	22lm/W	Gris
ES1015VERT ENG0600606000010	VERT	100lm	30lm/W	Gris
ES1015BLEU ENG0600606000008	BLEU	80lm	25lm/W	Gris