

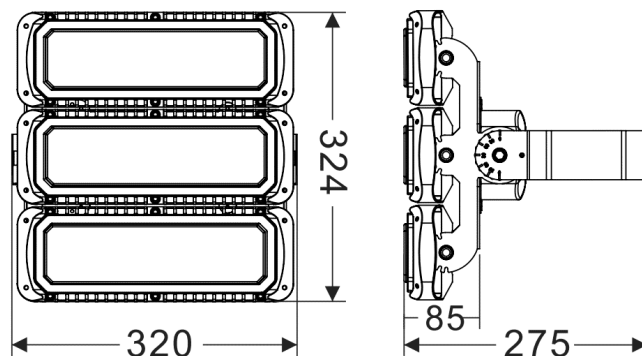

PE6230 230W

Projecteur LED symétrique



Caractéristiques techniques

LARGEUR	320,0mm
LONGUEUR	324,0mm
HAUTEUR	275,0mm
MATIÈRE	Aluminium, Polycarbonate
POIDS	6,4kg
TENSION D'ALIMENTATION	100-240Vac
PUISSANCE MAXIMALE	230,0W
CONDITIONNEMENT	1



Références

NOM COMMERCIAL RÉF. CONSTRUCTEUR	TEINTE	FLUX	EFFICACITÉ LUMINEUSE	TYPE DE VARIATION	COULEUR DU PRODUIT
PE6230NOIRBL30 ENG0800200000007	3000 °K	28250lm	120lm/W	Non variable	Noir
PE6230NOIRBL57 ENG0800200000008	5700 °K	28250lm	120lm/W	Non variable	Noir