

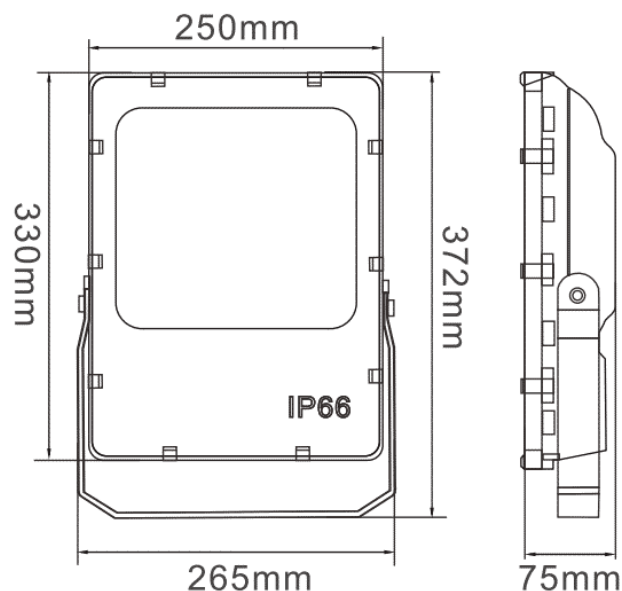

PE5072 72W

Projecteur LED symétrique



Caractéristiques techniques

LARGEUR	265,0mm
LONGUEUR	330,0mm
PUISSANCE MAXIMALE	72,0W
TENSION D'ALIMENTATION	100-240Vac
POIDS	4,5kg
MATIÈRE	Aluminium
HAUTEUR	75,0mm
CONDITIONNEMENT	1



Références

NOM COMMERCIAL RÉF. CONSTRUCTEUR	TEINTE	FLUX	EFFICACITÉ LUMINEUSE	TYPE DE VARIATION	COULEUR DU PRODUIT
PE5072BL30 ENG0800100000009	3000°K	8250lm	110lm/W	Non variable	Noir
PE5072BL57 ENG0800100000010	5700°K	9300lm	125lm/W	Non variable	Noir