

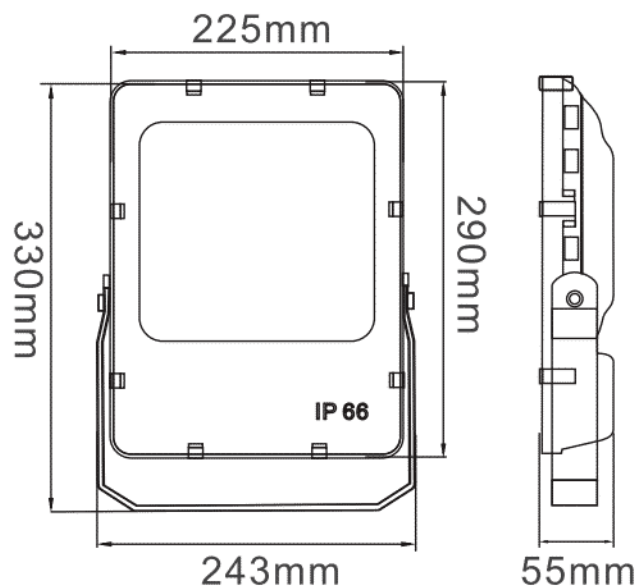

PE5050 50W

Projecteur LED symétrique



Caractéristiques techniques

LARGEUR	243,0mm
LONGUEUR	300,0mm
PUISSANCE MAXIMALE	50,0W
TENSION D'ALIMENTATION	100-240Vac
POIDS	3,1kg
MATIÈRE	Aluminium
HAUTEUR	55,0mm
CONDITIONNEMENT	1 pièce



Références

NOM COMMERCIAL RÉF. CONSTRUCTEUR	TEINTE	FLUX	EFFICACITÉ LUMINEUSE	TYPE DE VARIATION	COULEUR DU PRODUIT
PE5050BL30 ENG0800100000005	3000°K	6100lm	122lm/W	Non variable	Noir
PE5050BL57 ENG0800100000006	5700°K	6500lm	130lm/W	Non variable	Noir