

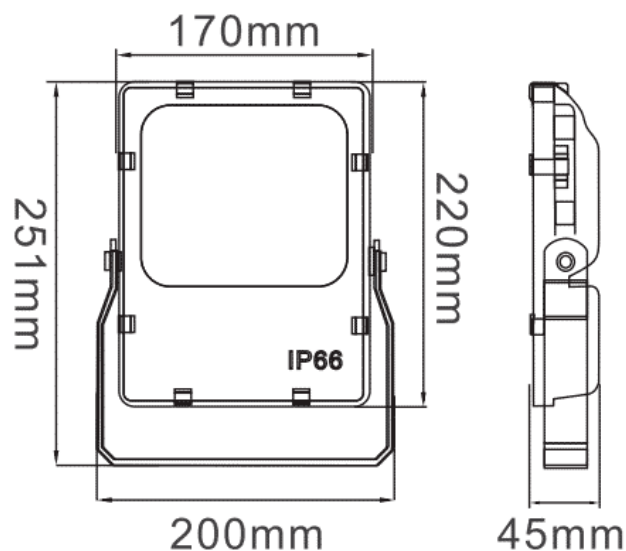

PE5025 25W

Projecteur LED symétrique



Caractéristiques techniques

LARGEUR	200,0mm
LONGUEUR	251,0mm
PUISSANCE MAXIMALE	25,0W
TENSION D'ALIMENTATION	100-240Vac
POIDS	1,7kg
MATIÈRE	Aluminium
HAUTEUR	45,0mm
CONDITIONNEMENT	1 pièce



Références

NOM COMMERCIAL RÉF. CONSTRUCTEUR	TEINTE	FLUX	EFFICACITÉ LUMINEUSE	TYPE DE VARIATION	COULEUR DU PRODUIT
PE5025BL30 ENG0800100000001	3000°K	2800lm	115lm/W	Non variable	Noir
PE5025BL57 ENG0800100000002	5700°K	3300lm	135lm/W	Non variable	Noir