

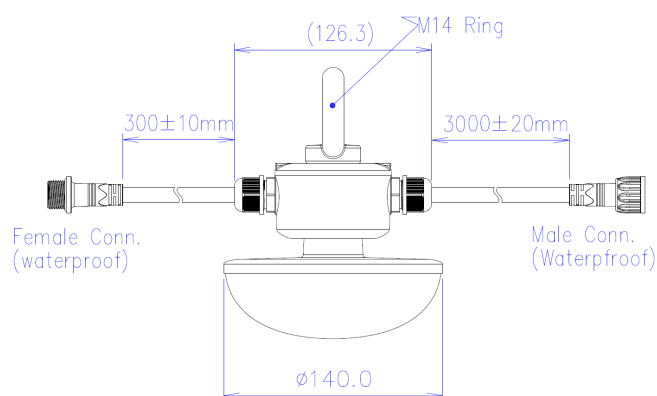

LA1011-O 24VAC 15W

Luminaire agricole



Caractéristiques techniques

DIAMÈTRE	140,0mm
MATIÈRE	Polycarbonate
POIDS	630,0g
TENSION D'ALIMENTATION	20-24Vac
PUISSANCE MAXIMALE	15,0W
CONDITIONNEMENT	1



Références

NOM COMMERCIAL RÉF. CONSTRUCTEUR	TEINTE	FLUX	EFFICACITÉ LUMINEUSE
LA1011-O-24-15BL27 ENG0810300000044	2700°K	1650lm	120lm/W
LA1011-O-24-15BL40 ENG0810300000045	4000°K	1650lm	120lm/W