

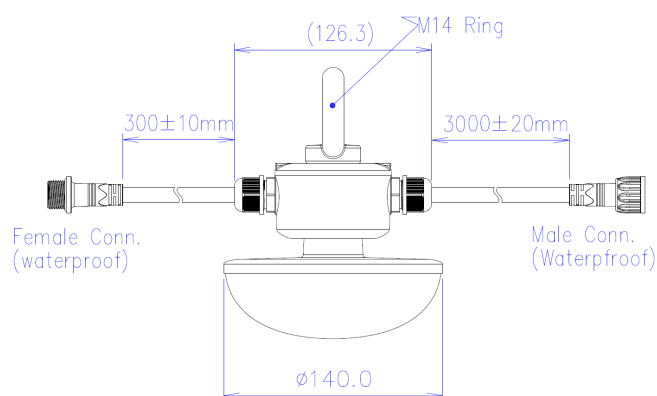

## LA1011-O 230VAC 15W

Luminaire agricole



### Caractéristiques techniques

DIAMÈTRE	140,0mm
MATIÈRE	Polycarbonate
POIDS	630,0g
TENSION D'ALIMENTATION	200-240Vac
PUISSANCE MAXIMALE	15,0W
CONDITIONNEMENT	1



## Références

NOM COMMERCIAL RÉF. CONSTRUCTEUR	TEINTE	FLUX	EFFICACITÉ LUMINEUSE
<b>LA1011-O-230-15BL27</b> ENG0810300000036	2700°K	1650lm	120lm/W
<b>LA1011-O-230-15BL40</b> ENG0810300000037	4000°K	1650lm	120lm/W