

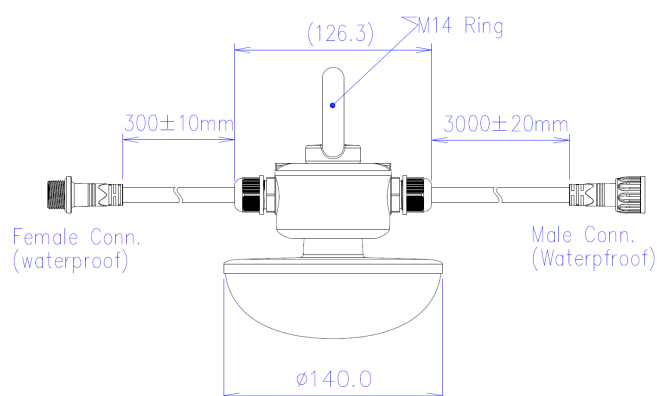

LA1011-O 230VAC 9W

Luminaire agricole



Caractéristiques techniques

DIAMÈTRE	140,0mm
MATIÈRE	Polycarbonate
POIDS	630,0g
TENSION D'ALIMENTATION	200-240Vac
PUISSANCE MAXIMALE	9,0W
CONDITIONNEMENT	1



Références

NOM COMMERCIAL RÉF. CONSTRUCTEUR	TEINTE	FLUX	EFFICACITÉ LUMINEUSE
LA1011-O-230-9BL27 ENG0810300000032	2700°K	1080lm	120lm/W
LA1011-O-230-9BL40 ENG0810300000033	4000°K	1080lm	120lm/W